

ALTN-水平T形彎頭(HORIZONTAL TEE ELBOW)

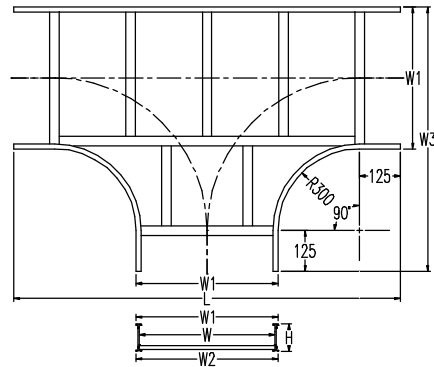

材 質 : 鋁合金 6063-T5
 表面處理 : 陽極處理
 MATERIAL : ALUMINUM ALLOYS 6063-T5
 FINISH : ALUMINUM ANODIC TREATMENT

異徑水平T形彎頭的CAT.NO.編碼方式如下:
 [例] 異徑水平T形彎頭 (900Wx500W)x100H
 CAT. NO.: ALTR-1095

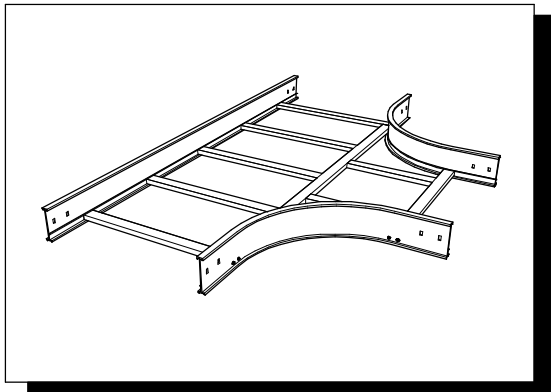
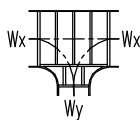

線槽Y軸寬Wy: 1=100mm, 2=200mm, 3=300mm, ..., 9=900mm, 0=1000mm
 線槽X軸寬Wx: 1=100mm, 2=200mm, 3=300mm, ..., 9=900mm, 0=1000mm
 邊槽高度H: 06=60mm, 08=80mm, 10=100mm, 12=120mm, 15=150mm, 20=200mm
 異徑水平T形彎頭

邊槽高度60H系列 (SIDE RAIL HEIGHT 60mm SERIES)

(Units: mm)

CAT. NO.	W	H	L	W1	W2	W3
ALTN-0601	100	60	971	121	123	546
ALTN-0602	200		1071	221	223	646
ALTN-0603	300		1171	321	323	746
ALTN-0604	400		1271	421	423	846
ALTN-0605	500		1371	521	523	946
ALTN-0606	600		1471	621	623	1046
ALTN-0607	700		1571	721	723	1146
ALTN-0608	800		1671	821	823	1246
ALTN-0609	900		1771	921	923	1346
ALTN-0610	1000		1871	1021	1023	1446

邊槽高度80H系列 (SIDE RAIL HEIGHT 80mm SERIES)

(Units: mm)

CAT. NO.	W	H	L	W1	W2	W3
ALTN-0801	100	80	971	121	123	546
ALTN-0802	200		1071	221	223	646
ALTN-0803	300		1171	321	323	746
ALTN-0804	400		1271	421	423	846
ALTN-0805	500		1371	521	523	946
ALTN-0806	600		1471	621	623	1046
ALTN-0807	700		1571	721	723	1146
ALTN-0808	800		1671	821	823	1246
ALTN-0809	900		1771	921	923	1346
ALTN-0810	1000		1871	1021	1023	1446